

## Flange Adapter

## Fig. 562

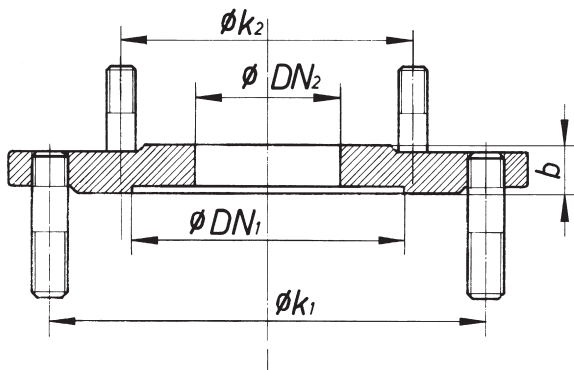

### Material:

of ductile cast iron GGG 500 – EN 1563  
epoxy fluidized bed coating  
250  $\mu$ m minimum coating thickness

Bolts: electrogalvanized

The transition from flanges of old design, no longer in compliance with the regulations, to flanges with actually binding flange standard is easily possible by means of a flange adapter 562. For example: 4-hole to 8-hole or 6-hole to 8-hole. Transitions to other pressure stages are easily possible, too.

| DN   | b  | K1 = K2 | Bolts  |           | Mass kg |
|------|----|---------|--------|-----------|---------|
|      |    |         | Number | Thread    |         |
| 80   | 28 | 160     | 8/4    | M 16 x 50 | 4,90    |
| 100* | 29 | 180     | 8/4    | M 16 x 50 | 6,20    |
| 100  | 47 | 180     | 8/6    | M 16 x 50 | 8,30    |
| 125* | 30 | 210     | 8/4    | M 16 x 50 | 6,20    |
| 150* | 36 | 240     | 8/6    | M 20 x 60 | 11,20   |
| 150  | 31 | 240     | 8/4    | M 20 x 60 | 10,60   |
| 200* | 32 | 295     | 8/6    | M 20 x 60 | 13,30   |
| 200  | 32 | 295     | 12/8   | M 20 x 60 | 13,40   |
| 250* | 32 | 350     | 12/8   | M 20 x 60 | 17,80   |
| 300* | 33 | 400     | 12/8   | M 20 x 60 | 20,10   |

\* Flange adapter DIN 2501 to standard of 1882

### Proposal:

Text of tender for flanged pipe fittings (e) ...of ductile cast iron GGG 400 (GGG 500) with all-over epoxy fluidized bed coating 250  $\mu$ m minimum coating thickness acc. to GSK testing guidelines.

Cf. make Krammer Fig. ...

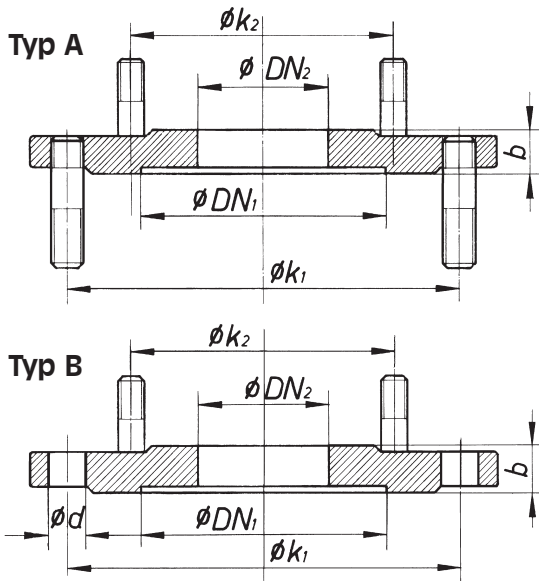

## Reducing Flange XR Fig. 563

### Material:

of ductile cast iron GGG 500 – EN 1563

epoxy fluidized bed coating

250  $\mu$ m minimum coating thickness

Bolts: electrogalvanized

By means of reducing flanges of type XR reductions from a given nominal pipe width to a considerably smaller one are possible. The short face-to-face dimension provides for an adaptation of the nominal width within very short distances. Double-flanged tapers of conventional face-to-face dimension and design are not necessary.

| DN      | Typ | b  | K1  | Bolts  |           | d  | K2  | Bolts  |           | kg/pc. |
|---------|-----|----|-----|--------|-----------|----|-----|--------|-----------|--------|
|         |     |    |     | Number | Thread    |    |     | Number | Thread    |        |
| 60/ 40  | A   | 46 | 135 | 4      | M 16 x 50 | —  | 110 | 4      | M 16 x 50 | 5,7    |
| 65/ 50  | A   | 47 | 145 | 4      | M 16 x 50 | —  | 125 | 4      | M 16 x 50 | 5,6    |
| 80/ 40  | A   | 30 | 160 | 8      | M 16 x 50 | —  | 110 | 4      | M 16 x 50 | 5,1    |
| 80/ 50  | A   | 28 | 160 | 8      | M 16 x 50 | —  | 125 | 4      | M 16 x 50 | 5,6    |
| 80/ 65  | A   | 28 | 160 | 8      | M 16 x 50 | —  | 145 | 4      | M 16 x 50 | 5,4    |
| 100/ 40 | A   | 30 | 180 | 8      | M 16 x 50 | —  | 110 | 4      | M 16 x 50 | 6,6    |
| 100/ 50 | A   | 27 | 180 | 8      | M 16 x 50 | —  | 125 | 4      | M 16 x 50 | 6,3    |
| 100/ 65 | A   | 30 | 180 | 8      | M 16 x 50 | —  | 145 | 4      | M 16 x 50 | 6,5    |
| 100/ 80 | A   | 30 | 180 | 8      | M 16 x 50 | —  | 160 | 4      | M 16 x 50 | 6,9    |
| 100/ 80 | A   | 47 | 180 | 8      | M 16 x 50 | —  | 160 | 8      | M 16 x 50 | 8,4    |
| 125/ 40 | B   | 30 | 210 | 8      | —         | 19 | 110 | 4      | M 16 x 50 | 8,4    |
| 125/ 65 | A   | 30 | 210 | 8      | M 16 x 50 | —  | 145 | 4      | M 16 x 50 | 8,2    |
| 125/ 80 | A   | 30 | 210 | 8      | M 16 x 50 | —  | 160 | 8      | M 16 x 50 | 8,0    |
| 125/100 | A   | 30 | 210 | 8      | M 16 x 50 | —  | 180 | 8      | M 16 x 50 | 7,6    |
| 150/ 50 | B   | 30 | 240 | 8      | —         | 23 | 125 | 4      | M 16 x 50 | 11,0   |
| 150/ 65 | B   | 30 | 240 | 8      | —         | 23 | 145 | 4      | M 16 x 50 | 10,8   |
| 150/ 80 | B   | 30 | 240 | 8      | —         | 23 | 160 | 8      | M 16 x 50 | 10,7   |
| 150/100 | A   | 30 | 240 | 8      | M 20 x 60 | —  | 180 | 8      | M 16 x 50 | 11,2   |
| 150/125 | A   | 30 | 240 | 8      | M 20 x 60 | —  | 210 | 8      | M 16 x 50 | 11,2   |
| 200/ 50 | B   | 30 | 295 | 8      | —         | 23 | 125 | 4      | M 16 x 50 | 14,9   |
| 200/ 65 | B   | 30 | 295 | 8      | —         | 23 | 145 | 4      | M 16 x 50 | 14,8   |
| 200/ 80 | B   | 30 | 295 | 8      | —         | 23 | 160 | 8      | M 16 x 50 | 14,7   |
| 200/ 80 | B   | 30 | 295 | 12     | —         | 23 | 160 | 8      | M 16 x 50 | 14,5   |
| 200/100 | B   | 30 | 295 | 8      | —         | 23 | 180 | 8      | M 16 x 50 | 15,0   |
| 200/100 | B   | 30 | 295 | 12     | —         | 23 | 180 | 8      | M 16 x 50 | 14,9   |
| 200/125 | B   | 30 | 295 | 8      | —         | 23 | 210 | 8      | M 16 x 50 | 13,7   |
| 200/150 | A   | 32 | 295 | 8      | M 20 x 60 | —  | 240 | 8      | M 20 x 60 | 16,5   |
| 200/150 | A   | 32 | 295 | 12     | M 20 x 60 | —  | 240 | 8      | M 20 x 60 | 16,6   |
| 250/ 50 | B   | 31 | 350 | 12     | —         | 23 | 125 | 4      | M 16 x 50 | 22,3   |
| 250/ 65 | B   | 31 | 350 | 12     | —         | 23 | 145 | 4      | M 16 x 50 | 22,2   |
| 250/ 80 | B   | 31 | 350 | 12     | —         | 23 | 160 | 8      | M 16 x 50 | 22,1   |
| 250/100 | B   | 31 | 350 | 12     | —         | 23 | 180 | 8      | M 16 x 50 | 21,9   |
| 250/125 | B   | 31 | 350 | 12     | —         | 23 | 210 | 8      | M 16 x 50 | 21,5   |
| 250/150 | B   | 31 | 350 | 12     | —         | 23 | 240 | 8      | M 20 x 60 | 20,0   |
| 250/200 | A   | 32 | 350 | 12     | M 20 x 60 | —  | 295 | 8      | M 20 x 60 | 21,3   |

Larger dimensions on request