

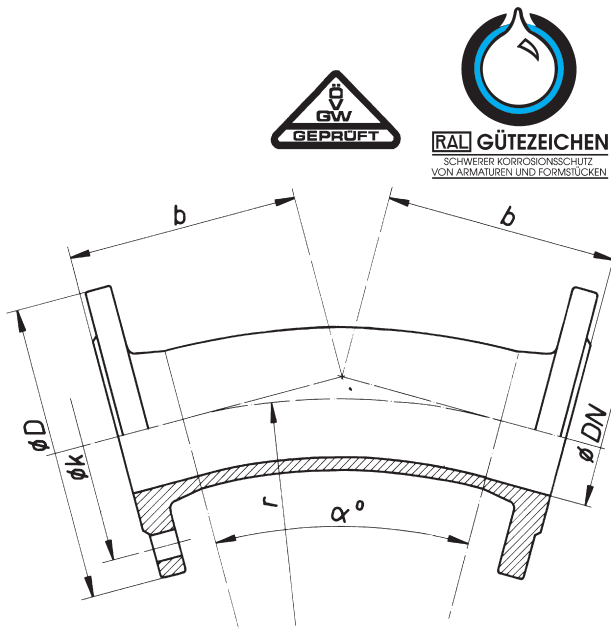

Flanged Pipe Fittings

Double-Flanged Bend FFK 30° Fig. 554



DN	b	D	k	Mass kg	
				GG	GGG
80	130	200	160	17,00*	9,50
100	140	220	180		11,90
125	150	250	210		11,10
150	160	285	240		19,60
200	160	340	295		28,60
250	210	400	350		45,00
300	255	455	400		63,00

* b = 180 mm

Larger dimensions on request

Blank Flange X Fig. 560

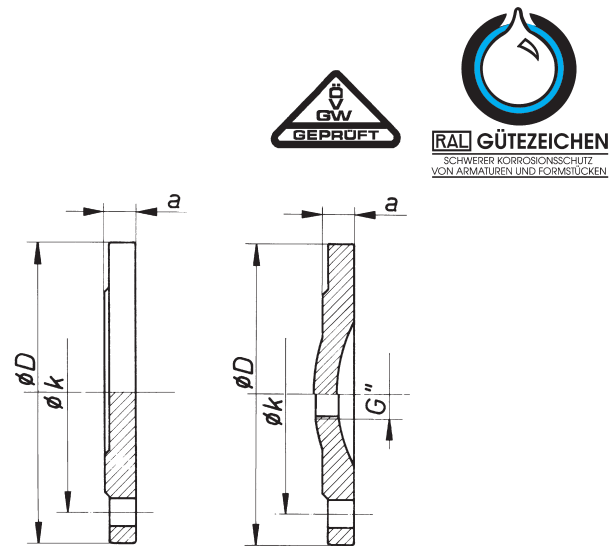

DN	a	D	k	Mass kg	
				GG	GGG
50	19,0	165	125		2,90
65		185	145		3,80
80		200	160		4,00
100		220	180		4,60
125		250	210		6,00
150	20,0	285	240		7,60
200		340	295		11,40
250		400	350		17,20
300	24,5	455	400		25,50

Threaded Flange XI Fig. 561

Dimension a, D, k as Fig. 560

Fig. 561

DN	Mass kg für GGG			
	G 1"	G 1 1/4"	G 1 1/2"	G 2"
50	2,80	2,70	2,60	2,50
65	3,70	3,60	3,50	3,40
80	3,90	3,80	3,70	3,60
100	4,50	4,40	4,30	4,20
125	5,90	5,80	5,70	5,60
150	7,50	7,40	7,30	7,20
200	11,30	11,20	11,10	11,00
250	17,00	16,80	16,60	16,40
300	25,30	25,10	24,90	24,70

Larger dimensions on request

to DN 250

higher than DN 250

Flange bore:

Acc. to EN 1092-2

Standard bore PN 16 to DN 150

For DN 200 and higher, PN 10

Accessories:

Flange gaskets

Fig. 830 + 831

Bolts and nuts

Fig. 841 + 842

Dimensions of flanges and bolts:

Sheet 9/1-1