



Fittings for PVC Pipes

Technical standard
acc. to sheet 4/1-1



RAL GÜTEZEICHEN
SCHWERER KORROSIONSSCHUTZ
VON ARMATUREN UND FORMSTÜCKEN

Flanged Sockets E-KS

Fig. 410

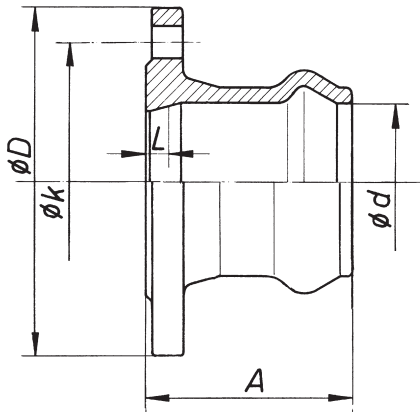

DN	d	A	L	D	k	Mass kg
50	63	108	20	165	125	3,00
65	75	115	14	185	145	3,80
80	90	122	14	200	160	5,70
100	110	133	15	220	180	6,00
125	140	147	19	250	210	9,17
150	160	159	15	285	240	11,00
200	225	192	34	340	295	17,00
250	280	220	41	400	350	25,20
300	315	240	49	455	400	35,00

Larger dimensions on request



RAL GÜTEZEICHEN
SCHWERER KORROSIONSSCHUTZ
VON ARMATUREN UND FORMSTÜCKEN

Flanged Spigot F-KS

Fig. 420

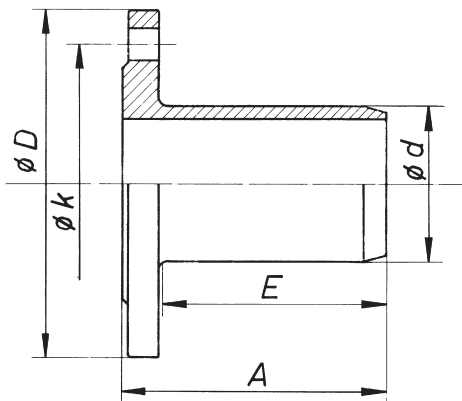

DN	d	A	E	D	k	Mass kg
50	63	110	97	165	125	3,20
65	75	117	101	185	145	4,50
80	90	128	110	200	160	5,10
100	110	141	120	220	180	6,20
125	140	159	135	250	210	8,60
150	160	171	145	285	240	11,00
200	225	192	165	340	295	17,40
250	280	247	218	400	350	27,50
300	315	267	240	455	400	32,50

Larger dimensions on request

Flange bore:

Acc. to EN 1092-2

Standard bore: PN 16 to DN 150

For DN 200 and higher PN 10

Dimensions of flanges and bolts:

Sheet 9/1-1