

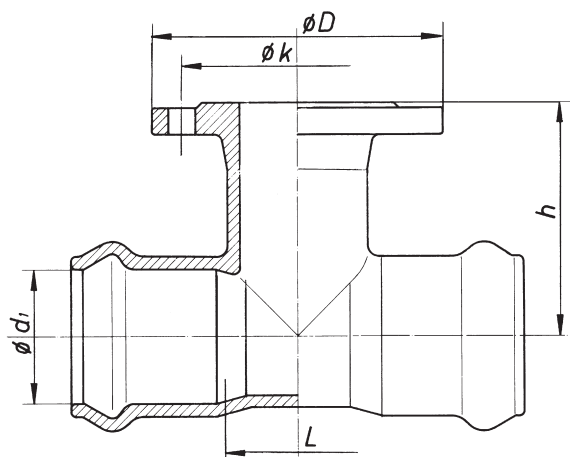

Technical standard
acc. to sheet 4/1-1



Double Socket Tee with Flanged Branch MMA-KS **Fig. 430**



Flange bore:

Acc. to EN 1092-2

Standard bore: PN 16 to DN 150

For DN 200 and higher PN 10

Accessories:

Restraint clamp	Fig. 472
Socket ring	Fig. 473
Flange gaskets	Fig. 830 + 831
Bolts and nuts	Fig. 841 + 842

Dimensions of flanges and bolts:

Sheet 9/1-1

DN ₁	DN ₂	d ₁	L	h	D	k	Mass kg	
							GG	GGG
50	50	63	63	140	165	125		6,60
65	50	75	66	140	165	125		7,80
	65	75	81		185	145		9,00
80	50	90	69	161	165	125		9,20
	65	90	84	161	185	145		10,50
	80	90	99	161	200	160		10,00
100	50	110	74	170	165	125		11,60
	65	110	89	172	185	145		12,00
	80	110	104	172	200	160		12,75
	100	110	124	172	220	180		13,45
125	50	140	80	176	165	125		15,10
	65	140	95	203	185	145		16,20
	80	140	110	187	200	160		14,10
	100	140	130	197	220	180		16,90
	125	140	155	205	250	210		21,80
150	50	160	82	200	165	125		19,80
	65	160	99	214	185	145		20,70
	80	160	116	199	200	160		20,25
	100	160	136	208	220	180		23,00
	125	160	161	218	250	210	26,50	
	150	160	186	235	285	240		28,00
200	80	225	128	251	200	160		26,80
	100	225	148	251	220	180		30,40
	125	225	173	245	250	210		28,20
	150	225	198	251	285	240		35,60
	200	225	248	251	340	295		39,30
250	80	280	140	282	200	160		40,50
	100	280	160	288	220	180		49,40
	150	280	210	288	285	240		49,40
	200	280	260	285	340	295		69,90
	250	280	310	287	400	350		69,30
300	80	315	152	305	200	160		61,70
	100	315	172	309	220	180		63,60
	125	315	197		250	210		65,00
	150	315	222		285	240		67,40
	200	315	272	292	340	295		76,80
	250	315	322	305	400	350		94,60
	300	315	372	309	455	400		90,00

Larger dimensions on request