

DUO

Fig. 240

acc. to EN 14339

GGG



Operating pressure: max. 16 bar (PN 16)
Outlets: DN 80: Port for standpipe of dimension B
DN 100: Port for standpipe of dimension A

Materials and surface protection:

Standpipe, claw and base of ductile cast iron, with all-over epoxy fluidized bed coating.

Rod tube of stainless steel.

Sealing piston of ductile cast iron, galvanized and partial vulcanized.

Spindle of stainless steel, grade 1.4021.

All other parts made of corrosion-resistant materials.

Complete drainage - remaining water zero (RW0).

All inside parts can be dismantled upwards without digging out the hydrant.

Simple installation due to loose flange and integrated flange gasket.

Alternatively with ball-type double closing.

The hydrant is operated by means of a valve key at square 27/32 via the rod assembly and the stainless steel spindle situated on top.





DUO

Fig. 240 GGG

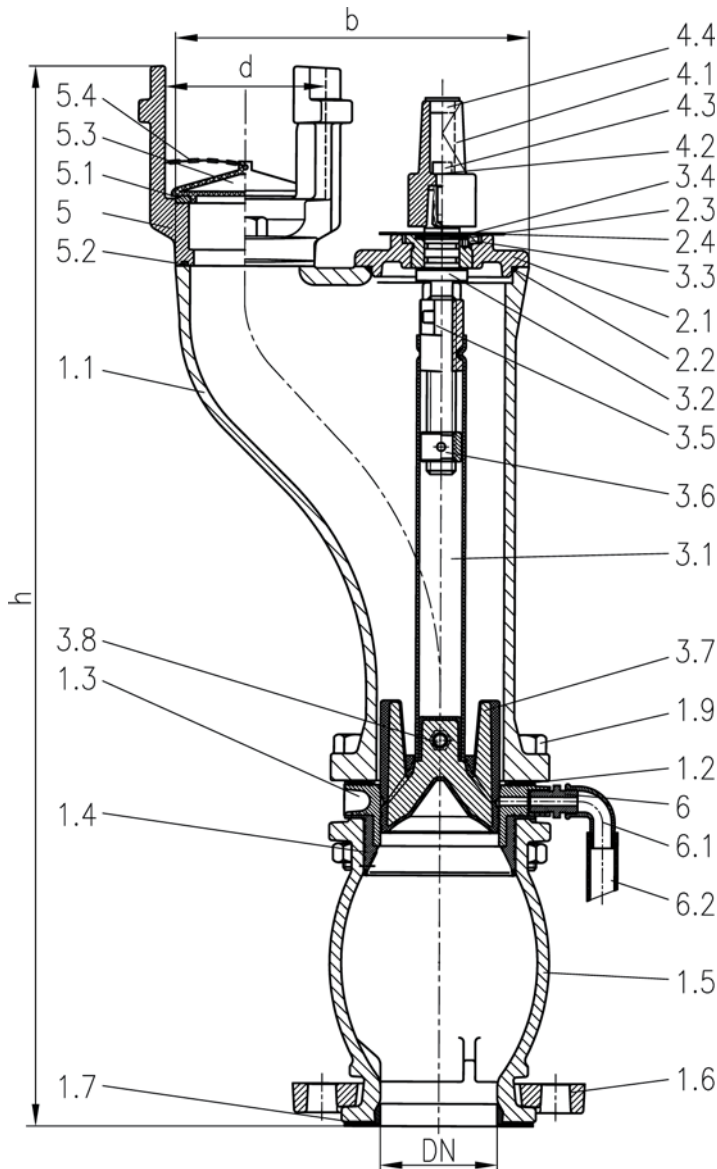

DN	pipecover m	h	b	d	kg
80	1,50	1230	242	110	39,5
80	1,25	980	242	110	35,5
80	1,00	730	242	110	31,5
100	1,50	1250	310	145	62,0
100	1,25	1000	310	145	55,5
100	1,00	750	310	145	49,0
100	---	700	310	145	46,0

1	hydrant standpipe assembly	
1.1	standpipe	GGG
1.2	pipe sealing	NBR
1.3	packing ring	1.4408
1.4	packing ring sealing	EPDM
1.5	base	GGG
1.6	loose flange	GGG
1.7	base sealing	EPDM
1.9	hexagonal screw M16x75	V2A
2	head plate assembly	
2.1	head plate	GGG
2.2	O-ring	NBR
2.3	friction washer	POM
2.4	specification plate	PVC
3	rod tube assembly	
3.1	rod tube	1.4301
3.2	spindle	1.4021
3.3	head bush	Ms 58
3.4	snap ring	V2A
3.5	spindle nut	Ms 58
3.6	stop nut	Ms 58
3.7	sealing piston	NBR
3.8	hexagonal screw M8x40	V2A
4	square cap assembly	
4.1	square cap	GGG
4.2	split washer	V2A
4.3	allen screw M8x16	V2A
4.4	isolating cap	PE
5	claw	GGG
5.1	claw ring	Ms 58
5.2	claw sealing	NBR
5.3	port cover	PE
5.4	chain	V2A
6	drainage	Ms 58
6.1	draining bend	Ms 58
6.2	discharge tube	PE

accessories:

Surface Box Oval
Duckfoot Bend
Operating Key
Hydrant Standpipe

Fig. 284
Fig. 290 – 294
Fig. 191
Fig. 287